

Oil Leakage Through a Valve Stem Seal

A. Aksenov, K. Iliine

TESIS, Russia

T. Luniewski,

Capvidia, Belgium

T. McCarthy, F. Popielas, R. Ramkumar

Dana Corporation, USA

Abstract: The simulation of oil leakage through a valve stem seal involves complex fluid-structure interaction between a moving valve stem (rigid body), oil and deformable seal (flexible body). In the simulation we used a full 3D model of a seal and considered a two-way fluid-structure coupling between the seal (structure) and oil (fluid). The seal deformation is modeled with Abaqus-explicit and oil leakage with FlowVision (finite volume based CFD code). The calculation domain is discretized by a volume Cartesian grid with dynamic local adaptation and uses a Euler grid approach for simulation of the moving boundary. At each physical time step the simulation domain is re-meshed and loads are exchanged between Abaqus and FlowVision(FV). Pressure values calculated by FV are transferred to Abaqus-explicit to calculate the resulting seal deformation. The data is automatically exchanged using Capvidia's Multi-Physics-Manager (MPM). The MPM links FV with Abaqus and transfers data via Abaqus user-subroutines. The approach described above allows us to perform detailed analysis of the oil leakage through a valve stem for various engine loads and operational conditions. The oil seal shape and material can be optimized to minimize the oil leakage.

Keywords: FSI simulation, Rubber seal, CFD coupling, Valve stem seal, Hyperelasticity, Lubrication.

1. Introduction

The first valve stem seal was invented in 1958. It was made up of Buna-N (NBR) Elastomer Body, Ring retainer, Teflon insert working in a 400°F temperature environment. In the early days before the invention of valve stem seals, there was higher oil consumption, excess blow by through the valves and high wear of the valves.

The design of the valve stem seal depends on several factors since the valve stem seal works in a very complex environment. Yet the primary function of the seal is to meter the oil in the right quantity against the pressure. It resists flowing oil to vacuum. Too much oil causes extensive emissions and deposits, while too little oil causes valve seat, face and guide wear. Therefore the solution is hydrodynamic lubrication. Oil metering rate is dependent upon the valve stem diameter, oil viscosity, and stem speed.

There are several other factors that affect the oil flow rate in the valve stem seal. One of the main factors that affect long term performance of the seal is the material aging due to oil, heat and temperature, which produces lots of challenges in the design process. Since the lab aging of the seals during the design process cuts into the design time, numerical processing is needed to predict the oil flow rate. Finite element analysis (FEA) shows how the seal deforms under installation and working conditions of the engine and also determines the contact pressure between the seal and the stem that in turn determines the oil flow rate. FEA can also be used to observe the difference in contact pressure due to the changes in material properties due to aging. Computational fluid dynamics (CFD) methods provide calculations of the oil metering rate in channel formed by stem and deformed seal. But FEA or CFD techniques alone are unable to predict the amount of oil flow due to pressure changes between the top and bottom of the seal. Therefore the Fluid Structure Interaction (FSI) techniques is necessary to provide a comprehensive study the oil flow rate in the seal.

The FSI technique uses ABAQUS to predict the stem seal deformation and FlowVision to calculate the oil flow. Two-way interaction between ABAQUS and FlowVision is managed by the Multi-Physics Manager. The FSI technique couples the CFD and FEA simulation domains. The link to ABAQUS is implemented using Abaqus user subroutines and does not involve any other intermediate data structures.

2. Oil Stem Seal

Construction of a typical valve seal is shown in Figure 1. The main parts of the valve seal are the sealing lip, Garter spring or the R-ring and the retainer. The retainer holds the sealing element in place and also stabilizes the sealing element by distributing the installation load. Types of sealing element can be single lip and multi-lip.

The main functions of the sealing lip are controlling oil flow through the seal, emission control, wear reduction, eliminating stem/guide blow up. The design of the valve stem seal depends on the physical dimensions, manifold pressures, desired metering rate, and engine specifications.

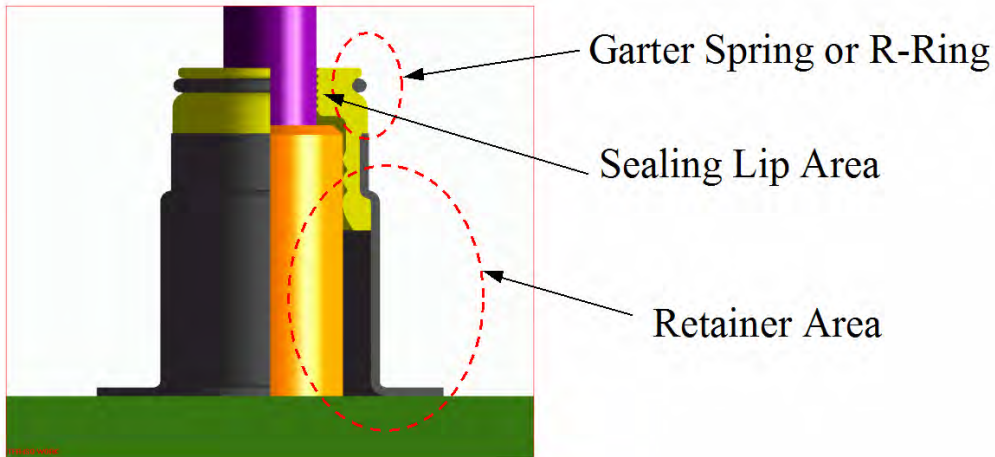

Figure 1 Nomenclature of a Valve Stem Seal

In the valve stem seal the fluid viscosity alone is not sufficient to maintain an oil film between the stem and the seal. The film is established between the stem and the seal by the dynamic motion, due to the pressure generated internally and is referred to as hydrodynamic lubrication. In hydrodynamic lubrication a fluid film is formed by the relative surface motion between the stem and the seal. Shear stress in this fluid film results in contact pressure between stem and seal. The value and distribution of the contact pressure in stem-seal clearance affects on the main characteristics of the valve seal.

The contact pressure distribution depends on many factors, among them: form of the channel between the seal lips, the stem, r-ring or Garter spring position, material properties, and manifold pressure. High manifold pressure reduces the oil flow but leads to stem/guide blow-by.

A close-up of the one-lip stem seal is shown in Figure 2. We assume in our simulation that the entire stem-seal clearance is filled by oil. The stem is moving up and down with a frequency depending on the engine rotation. Pressure in point P2 corresponds to manifold pressure, P1 – atmospheric pressure in the valve train area.

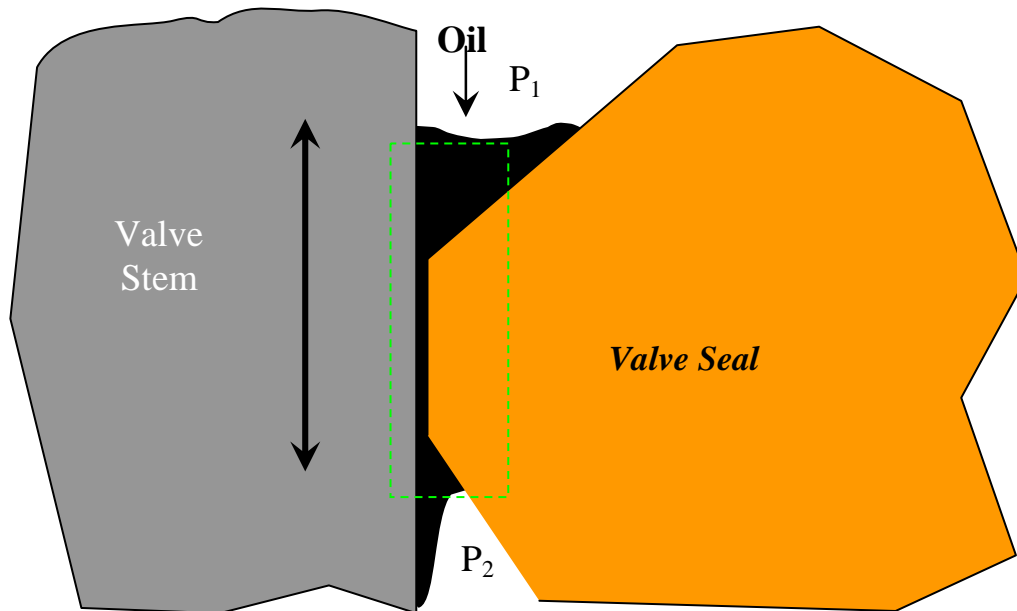

Figure 2 Close up of the seal in operation

3. Numerical Method

Subgrid geometry resolution method. FlowVision uses rectangular finite-volume grid with local adaptation. (Figure 3) (Aksenov et al, 1996, Aksenov et al, 1998). The subgrid resolution is a Boolean operation between a Cartesian volume grid and curvilinear boundary defining the computational domain. The computational domain boundary is represented by a set of planar facets describing the valve stem and the valve seal. The valve seal is described by a volumetric finite element mesh. The valve seal boundary is formed by the outside faces of the finite elements and provides a direct link between fluid grid and FE mesh (see for details Aksenov et al, 2004).

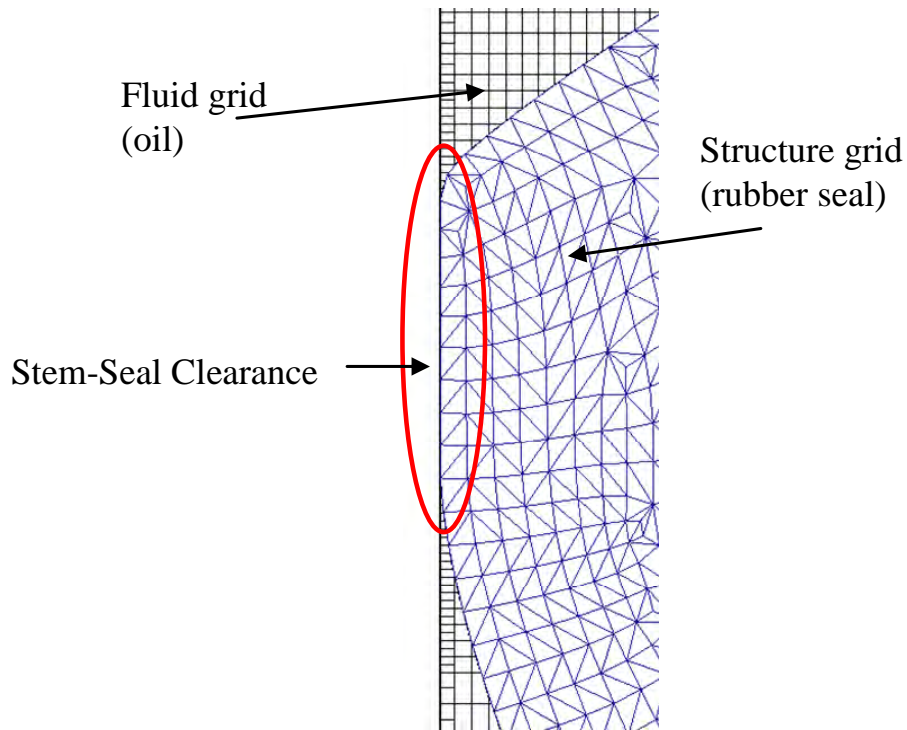

Figure 3 Rectangular grid with local adaptation used for fluid flow simulation

Governing Equations. Modeling structure is performed by Abaqus/Explicit to take into account dynamic characteristics of the seal. Governing equations of deformed structure in terms of discrete finite-element model are following:

$$(1) \quad \mathbf{M} \frac{d^2 \mathbf{u}}{dt^2} = \mathbf{P} + \mathbf{P}_f - \mathbf{I},$$

where \mathbf{M} is the mass matrix of the finite element system, \mathbf{u} – displacement of the nodes. \mathbf{P} is non-hydrodynamic force acts on the structure, \mathbf{I} is the internal element force. \mathbf{P}_f is hydrodynamic force equals

$$(2) \quad \mathbf{P}_f = P \cdot \mathbf{s},$$

where \mathbf{s} is vector-area of external face of the element, P is a fluid pressure, calculated from Navier-Stokes equations. Navier-Stokes equations in integral form applied to calculation grid of fluid flow domain are:

$$(3) \quad \frac{d}{dt} \iint_{\Omega, \tau} \mathbf{V} d\Omega dt + \oint_S \mathbf{V}(\mathbf{V} - \mathbf{W}) d\mathbf{s} = - \oint_S \frac{P}{\rho} d\mathbf{s} + \oint_S D d\mathbf{s}.$$

Integral form of continuity equation is

$$(4) \quad \oint_S (\mathbf{V} - \mathbf{W}) d\mathbf{s} = 0,$$

where \mathbf{V} is fluid velocity, μ - viscosity, ρ - density, $\mathbf{W} = \dot{\mathbf{u}}$ - velocity of the structure surface, Ω and S is a volume and a surface of the cell of fluid flow computational domain, τ is time increment for fluid flow simulation.

Coupling FEA and CFD. Described numerical method uses consecutive 2-way coupling procedure. Information exchange between ABAQUS and FlowVision is performed at some time moments T^n and T^{n+1} defined by user on a base of specific characteristics of the solving problem. Time step $\Theta^{n+1} = T^{n+1} - T^n$ is called FSI time step. The FSI time step consists of several ABAQUS and FlowVision time increments. The FSI coupling includes the following steps:

- Initially Equation 1 is calculated by ABAQUS to obtain displacement of the nodes \mathbf{u}^{n+1} corresponding to time step Θ^{n+1} . Fluid pressure P^n is obtained from previous time step Θ^n and assumed constant during the time step Θ^{n+1} .
- Displacement of the nodes \mathbf{u}^{n+1} is transferred to FlowVision; velocity of the deformed surface \mathbf{W} is calculated.
- Equations 3 and 4 are calculated by FlowVision to obtain fluid loading on the structure.
- Pressure P^{n+1} is transferred to ABAQUS at the end of all FlowVision time increments at moment Θ^{n+1} .

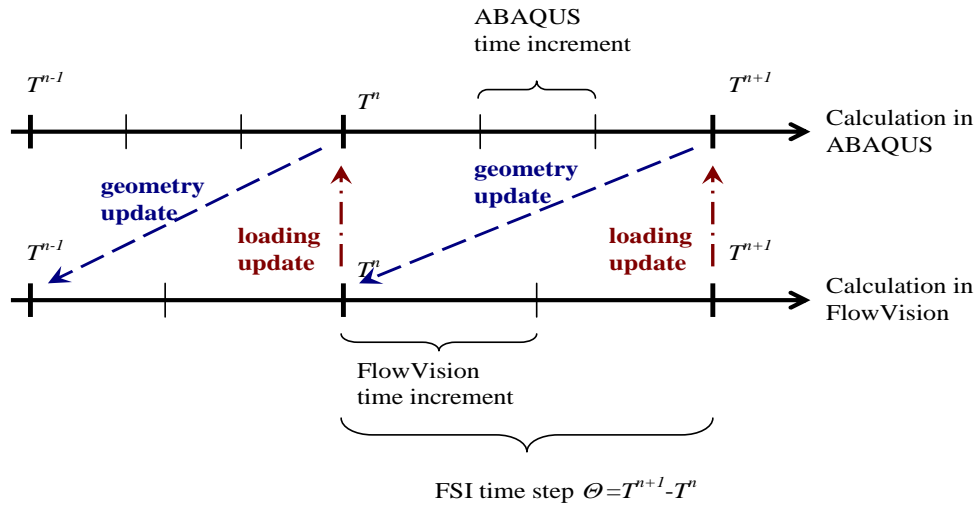

Figure 4 Time stepping procedure

Numerical method for solving equations of fluid dynamics. FlowVision uses an Euler approach to solve fluid dynamics equations in the computational domain with moving boundaries. To take into account boundary motion along non moving grid a special numerical method is used. The objective of this method provides the possibility to simulate fluid flow stably and conservatively at any time increment and at arbitrary motion of the rigid body, including boundary collisions. Boundary collisions are very important for solving the contact between the seal and the stem.

Due to the body motion the fluid computational grid is changing, New grid cells can be born , removed or change their form. Designate grid at time t^n as G^n , volume of the cells as Ω^n . Note, that during motion of the body from time moment t^n to t^{n+1} a surface of the cell is changed. Designate S^{n+1} as average area of the cell surface over the time increment $\tau^{n+1} = t^{n+1} - t^n$. This area is linked with cell volume change in time by expression:

$$(5) \quad \oint_S \mathbf{W} ds = \frac{d\Omega}{dt}$$

Let's write formal approximation of (Equation 3) and (Equation 4)

$$(6) \quad \frac{\Omega^{n+1} \mathbf{V}^{n+1} - \Omega^n \mathbf{V}^n}{\tau} + \oint_{S^{n+1}} \mathbf{V}^{n+1} (\mathbf{V}^n - \mathbf{W}^n) ds = - \oint_{S^{n+1}} P^n / \rho ds + \oint_{S^{n+1}} D^{n+1} ds$$

and continuity equation

$$(7) \quad \oint_{S^{n+1}} (\mathbf{V}^{n+1} - \mathbf{W}^{n+1}) ds = 0 ,$$

or applying (5) for (7), we get another form of continuity equation

$$(8) \quad \oint_{S^{n+1}} \mathbf{V}^{n+1} ds = \frac{\Omega^{n+1} - \Omega^n}{\tau},$$

Apply split method (developed for stationary computational grid, see (Belotserkovsky, 1994)) for solving equations (Equation 5, 8). Define divergence velocity at the center of the cell $\tilde{\mathbf{V}}$ and at its faces $\tilde{\mathbf{V}}_s$ as following:

$$(9) \quad \frac{\tilde{\mathbf{V}} - \mathbf{V}^n}{\tau} = \frac{1}{\Omega^{n+1}} \left(- \oint_{S^{n+1}} \frac{P^{n+1}}{\rho} ds + \oint_{S^{n+1}} \frac{P^n}{\rho} ds \right)$$

$$(10) \quad \frac{\tilde{\mathbf{V}}_s - \mathbf{V}_s^n}{\tau} = -\nabla \frac{P^{n+1}}{\rho} + \nabla \frac{P^n}{\rho},$$

where gradient ∇ is defined on the face of the cell. This velocity satisfies the continuity Equation 8. Integrate (Equation 10) over cell surface and apply Equation 8, get following expression to define pressure at $n+1$ time increment:

$$(11) \quad \frac{\Omega^{n+1} - \Omega^n}{\tau} - \oint_{S^{n+1}} \mathbf{V}^n ds = \tau \left(- \oint_{S^{n+1}} \nabla \left(\frac{P^{n+1}}{\rho} \right) ds + \oint_{S^{n+1}} \nabla \left(\frac{P^n}{\rho} \right) ds \right)$$

Velocity \mathbf{V}^{n+1} is calculated from convective-diffusion equation that is analog of (6)

$$(12) \quad \frac{\Omega^{n+1} \mathbf{V}^{n+1} - \Omega^n \tilde{\mathbf{V}}}{\tau} + \oint_{S^{n+1}} \rho \mathbf{V}^{n+1} (\mathbf{V}_s - \mathbf{W}^{n+1}) ds = - \oint_{S^{n+1}} \frac{P^{n+1}}{\rho} ds + \oint_{S^{n+1}} D^{n+1} ds,$$

Numerical algorithm of solving Navier-Stokes equations begins from solving elliptic equation (Equation 11), after that calculating (Equation 9 and 10), and at the end (Equation 12).

Clearance Model. To resolve the small clearance between stem and seal a Clearance Model is used. This model is specially developed to accurately resolve thin clearance when grid refining is not practical. The model is applied in 'gap cells'. A gap cell is formed by an intersection of the fluid grid cell with two boundaries of the computational domain. (Figure 4). The distance between those boundaries is smaller than the grid cell size. In this way the clearance is approximated by one across grid cell. As the clearance is small the corresponding Reynolds number is also small, and Poiseuille flow inside the gap cell can be assumed. In this case the drag force inside the cell is easily calculated and can be added to the momentum transfer equations in such a cell.

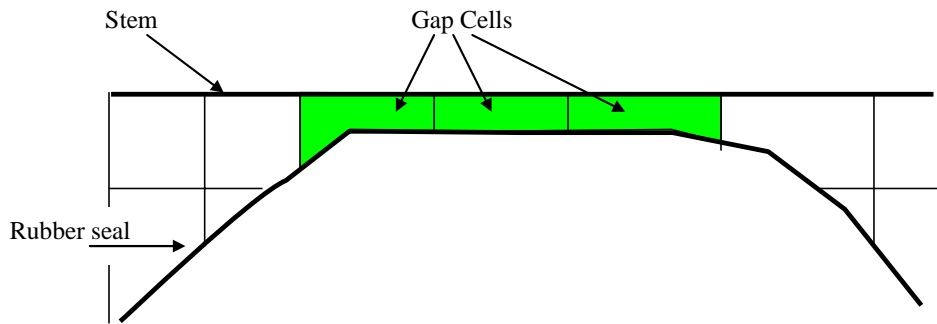

Figure 4 Clearance Model to resolve gap between stem and seal

Multi-Physics Manager (MPM). To exchange and the control data transfer between Abaqus and FlowVision the Multi-Physics manager is used. The Multi-Physics manager is an optional FlowVision module. Link to ABAQUS is performed via user subroutines VDLOAD and VUINTER. VDLOAD supplies pressure loads from the fluid flow; VUINTER is used to obtain the node positions. The FSI simulation is performed in the following steps:

- Create FlowVision project using INP file with ABAQUS volume mesh
- In the ABAQUS project you need to specify a call for VDLOAD and VUINTER user subroutines for the external surface of the deformable mesh.
- Specify a time step for the data exchange between ABAQUS and FlowVision.
- Start MPM.
- The MPM automatically starts sequentially ABAQUS and FlowVision. Results are stored in ABAQUS and FlowVision databases.
- The user can visualize the FSI results using the FlowVision post processor and animation module.

4. Results

3D simulation of oil flow in the gap between the deformed seal and stem was performed on a 10 degree section. The ABAQUS and FlowVision models and FSI results are described below.

4.1 Problem Statement in ABAQUS

4.1.1 ABAQUS model

The finite element model shown in Figure 5 consists of a rubber seal (hyper-elastic material with density of 10^{-6} kg/mm³), steel ring spring and metal retainer (density 10^{-5} kg/mm³, Young's

modulus 102500 MPa, Poisson's ratio 0.25). The definition of boundary conditions is shown in Figure 6.

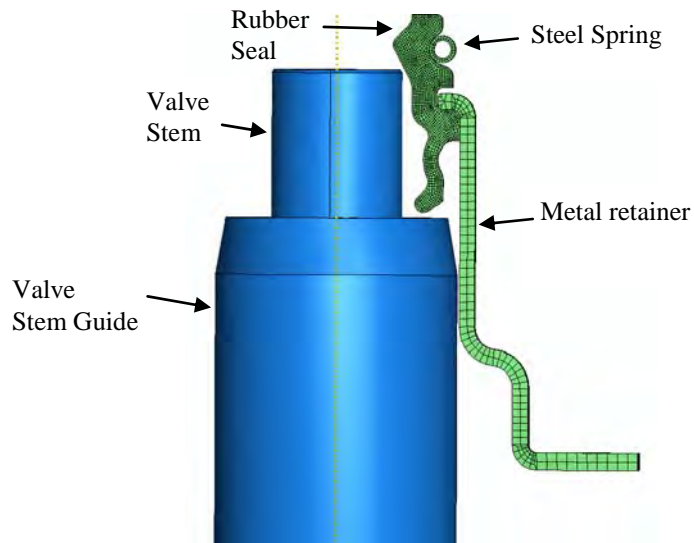

Figure 5 Finite-element grid of the valve seal

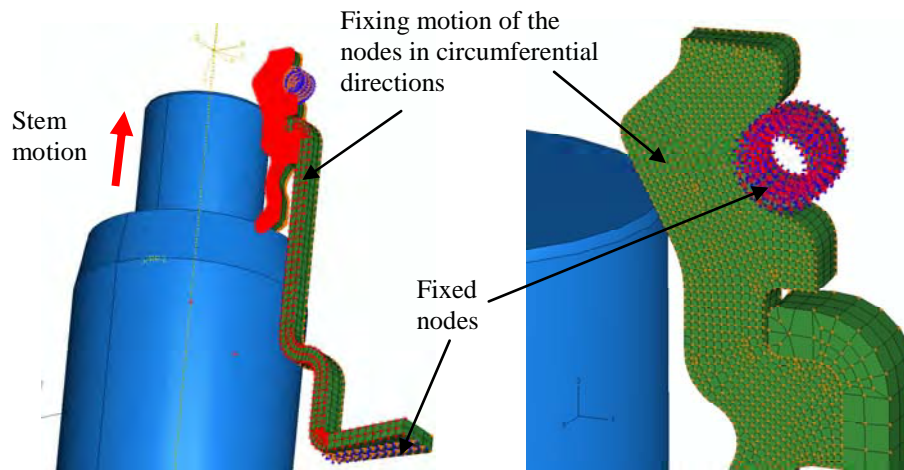

Figure 6 Boundary conditions for structure

4.1.2 ABAQUS – valve seal initial deformation

The first step in the FSI simulation is the steady-state solution resulting from the contact between the valve seal and the valve stem. The rubber seal deformation is shown in Figure 7. One can see that rubber seal is closely fitted to the stem without any clearance. This deformation is used as the initial condition for next FSI simulation step described below.

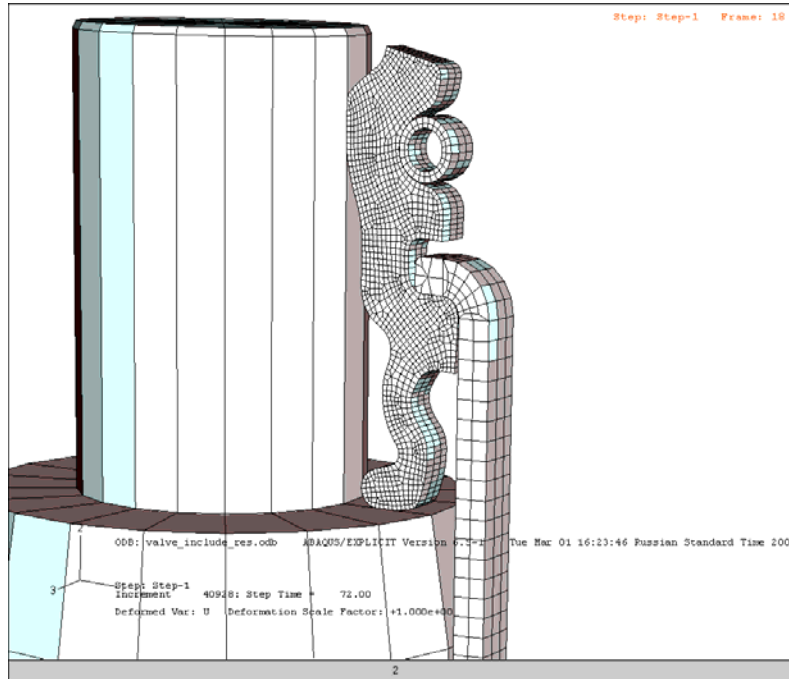

Figure 7 Deformation of the rubber seal at the end of non-FSI time step

4.1.3 FlowVision model

CFD model is shown in Figure 8, a, for the same 10 degree section as in ABAQUS model. The domain contains the rubber seal (FE model) that forms the fluid flow channel between the outer valve seal surface and the moving stem wall.

The calculation of the finite-volume grid is shown in Figure 8, b. The grid is refined at the inlet/outlet of the clearance formed between the stem and the seal. Grid refinement inside the clearance is not necessary as we use gap cells to model the clearance. For the gap cells the Clearance Model was used.

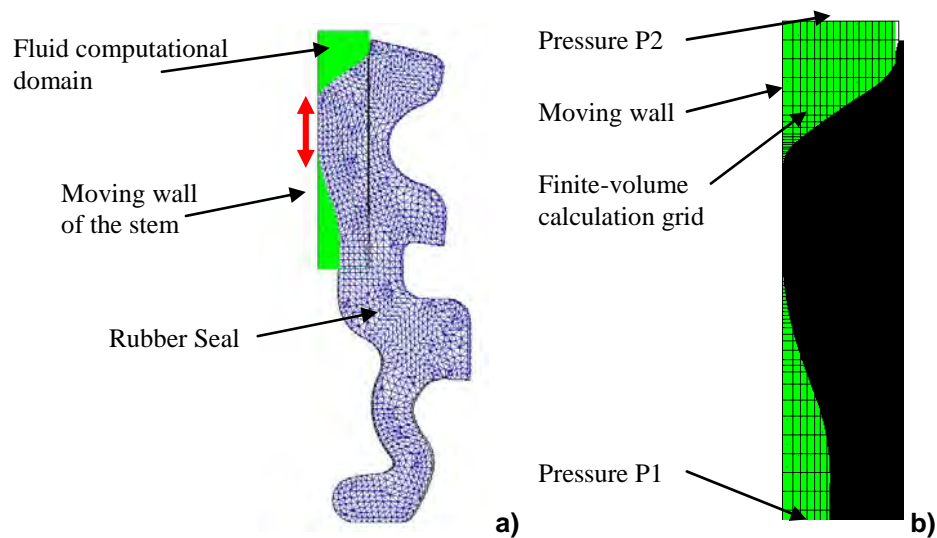

Figure 8 CFD model. a) Computational domain, b) finite-volume grid

Boundary conditions of the fluid computational domain is shown in Figure 8,b. The motion of the stem is modeled as an oscillating wall. At top boundary of the computational domain the pressure P2 and at bottom pressure P1 are applied (see Figure 1).

To start the FSI simulation the initial small clearance between stem wall and the seal is defined. This is needed to form the initial channel filled by the oil. To minimize errors this initial clearance is specified smaller than the actual operational clearance. For this simulation we defined the initial clearance to 1 μm . During the simulation the clearance expands to the normal operational value (10-20 μm).

4.1.4 FSI simulation

The simulated problem is unsteady as the valve stem is oscillating. Absolute pressure P1 and P2 are equal to 1 and 2 atmosphere. Stem speed has the following time dependence $0.8 \sin\left(\frac{2\pi t}{0.12}\right)$.

Oil pressure and velocity are presented in Figure 9. At this time the stem is moving up with speed 0.64 m/s. Pressure field distribution is presented in Figure 9a, and oil velocity in Figure 9b. One can observe that stem motion causes high pressure (~ 10 atmospheres) and creates force (~ 14 N) moving the seal away from the stem.

Instant leakage through valve seal is shown in Figure 10. Positive values of leakage correspond to flow from P1 to P2 (Figure 1). Average oil leakage (solid line in Figure 10) is positive in spite of the negative pressure difference $P2 > P1$. The oil flow against the pressure is determined by the

shape of the channel formed between the valve seal and the stem - slope of seal wall to stem is less in the down stroke of the valve stem, and greater in the upstroke

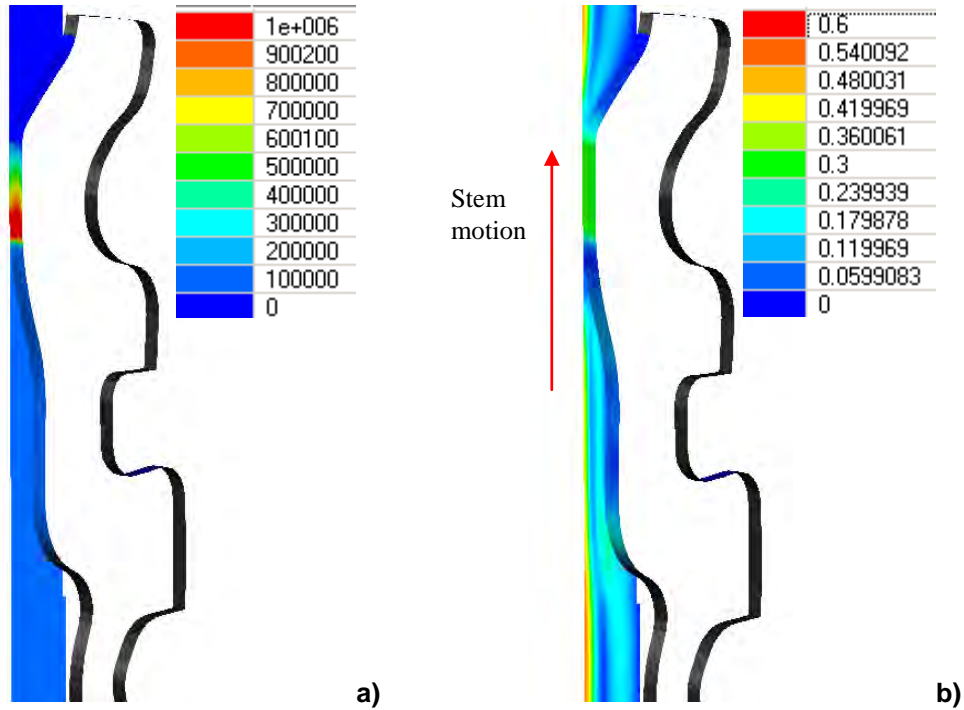

Figure 9 Oil flow; a) pressure distribution, Pa, b) oil speed, m/s.

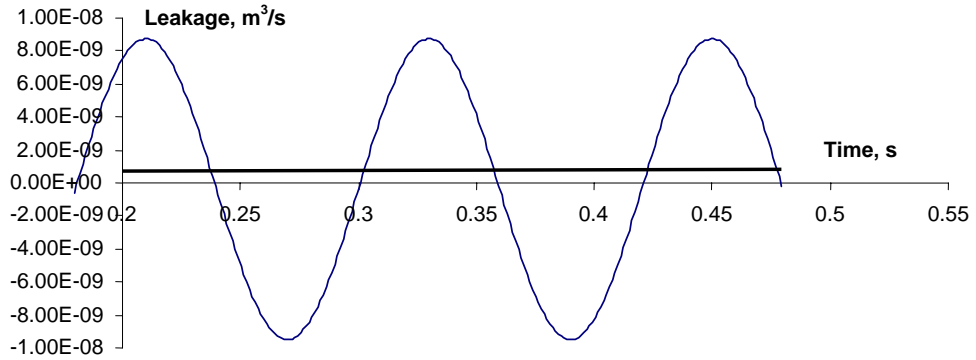

Figure 10 Leakage through valve seal and average leakage (solid line) over time

5. Conclusion

The simulation of the typical valve stem seal used in a combustion engine is performed. This simulation is based on two numerical approaches – finite element for modeling deformed structure (seal) and finite volume for modeling the oil flow between a stem and a seal. Deformation of the seal is calculated in Abaqus FEA code and oil flow in FlowVision CFD code. The two-way coupling of these two different simulation methods is performed using the subgrid resolution method. This approach allows elimination of intermediate structures. A coupling is implemented using only Abaqus user subroutines.

The modeling of thin clearance between the stem and the valve seal is solved by using FlowVision hybrid modeling capability (Clearance Model in gap cells).

The proposed simulation approach allows investigations of oil leakage as function of time, valve seal shape, engine speed and rubber aging process. The obtained results are corresponding well with the experiments, which prove the method usefulness for the design and optimization of valve stem seals. The numerical simulation will decrease expensive and time consuming experiments to predict change of the stem seal operation as function of rubber aging characteristics.

6. References

1. A. Aksenov, A. Dyadkin, T. Luniewski, V. Pokhilko Fluid Structure Interaction analysis using Abaqus and FlowVision, Proc. Abaqus User Conference, 2004, Boston, USA, 2004
2. Aksenov A, Dyadkin A, Pokhilko V. Overcoming of Barrier between CAD and CFD by Modified Finite Volume Method, Proc. 1998 ASME Pressure Vessels and Piping Division Conference, San Diego, ASME PVP-Vol. 377-1., 1998
3. Aksenov A., Dyadkin A., Gudzovsky A., 1996, “Numerical Simulation of Car Tire Aquaplaning”. Computational Fluid Dynamics '96, J.-A. Desideri, C.Hirsch, P.Le Tallec, M.Pandolfi, J.Periaux eds, John Wiley&Sons, pp. 815-820.
4. Belotserkovsky, 1994 Numerical Methods in Continuum Mechanics, Moscow, Fizmatlit, 2nd edition, p.441.